

Installation Instructions for OSS Sensors in Sanitary Assemblies

Cable	4 AWG, 2 Wire, Tef. Ins.
-------	--------------------------

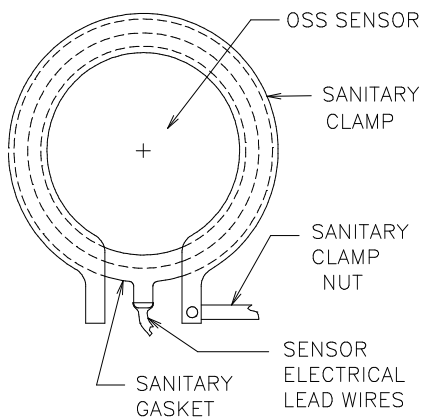
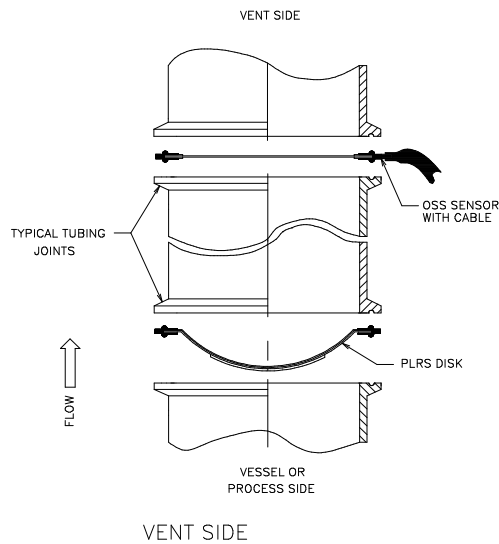

Electrical Data

Max Current	150 mA
Temperature Range	-60° to 300°F
Max Pre-burst Resistance	50 Ohms

This sensor may be used at any voltage provided the maximum current requirements are not exceeded.

Materials

Gasket	EPDM, White Silicone, and Viton are standard, special materials available upon request.
Membrane	Teflon
Circuit Track	316 SS

Installation Instructions for OSS Sensors in Sanitary Assemblies

BURST PRESSURE

The OSS sensor is designed to open at pressure of 3 in. W.C. or greater.

INSTALLATION

1. The OSECO Model OSS burst disk sensor is a fragile instrument. **HANDLE CAREFULLY - DO NOT FLEX OR MOVE CENTRAL PORTION OF SENSOR.**
2. Verify that the work area is safe. Do not loosen fittings when the tubing system or vessel is pressurized. Use appropriate personnel protection procedures for process media.
3. The OSECO Model OSS burst disk sensor has an integral gasket seal designed to fit between standard sanitary fittings. The OSS burst disk sensor size is the same nominal size as the sanitary clamp securing the installation, i.e., 3" OSS requires a 3" clamp.
4. Verify sensor resistance is less than 50 ohms before and after installation.
5. Verify mating surfaces are clean and free of adverse scratches or debris before installation.
6. Always install sensor on the vent side (downstream) of the rupture disk. The discharge from all pressure relief devices should be routed to a safe disposal area. Verify sensor cable is located as shown in above diagram and is not obstructed or cut by the sanitary clamp. Use cable support to isolate tension stresses from the sensor. Protect the OSS sensor from the weather. Use clamp torque specified by the fitting manufacturer. **IMPORTANT: In horizontal tubing, install OSS sensor with cable at bottom of fitting, i.e. 6 o'clock position.**
7. After installation, connect the OSS sensor to a compatible, quick acting, latching alarm system. The sensor is a normally closed device. The alarm system should be wired to indicate a burst disk assembly when the sensor creates an open circuit. An open circuit is created when flow in the tubing, released by a burst rupture disk, opens the sensor circuit.
8. After the OSS sensor is connected to the alarm system, verify that the system is working properly by disconnecting the sensor cable, simulating an open circuit condition. Reconnect the cable after test. Periodic sensor system testing is recommended. When using an OSECO alarm monitor, follow OSECO's recommended "BDA System Verification Procedure."